



Wireless Sensor Networks – A Sensor Fabric for Remote Condition Monitoring and Asset Optimization

The Next Generation



John Dorn

Which is Correct ?

1. A "**Mote**" is a fairy character
in William Shakespeare's play, "A Midsummer Night's Dream."
2. A "**Mote**" a small particle; a speck
Term was first used by Kris Pister to describe his Smart Dust
radio/sensors Term was later adopted by Dave Culler (TinyOS
author)
3. A "**Mote**" is a Wireless Mesh Low Power Sensor Node,
in a **wireless sensor network** that is capable of performing some
processing, gathering sensory information and communicating with
other connected nodes in the network* .

*Wikipedia

What is a Mote?

Technology:

- Hardware Components:
 - Active radio frequency transceiver
 - 433MHz, 900MHz, 2.4GHz
 - 19.2kbps - 250kbps
 - 200 – 1000 feet LOS, outdoors
 - 8-, 16-, 32-bit Microprocessor
 - 8051, TI MSP430, Atmel ATmega128L, ARM920T
 - Memory: Flash & DRAM
 - 10kB-512kB RAM, 64kB-4MB Flash
 - Sensors
 - A/D & D/A converters, 10, 12, 16-bit
- Software Components:
 - Embedded programmable runtime:
 - Executes protocols: MAC, network, security
 - Executes application-specific code
 - Mostly proprietary
 - TinyOS/TinyDB & MANTIS open source
 - C-like programming, Java is emerging



EMS100 from Sensicast



RTD100 from Sensicast



Tmote Sky/TelosB from MotelV/Crossbow



Mica2 from Crossbow



Sun SPOT from Sun

Wireless Sensor Network

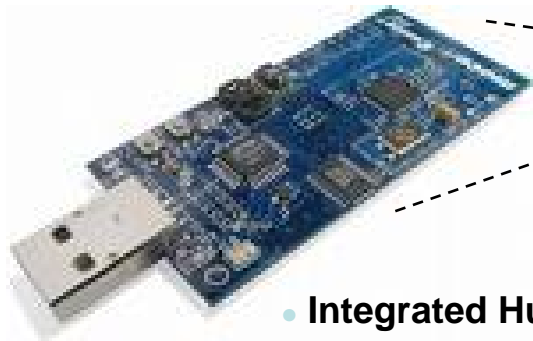
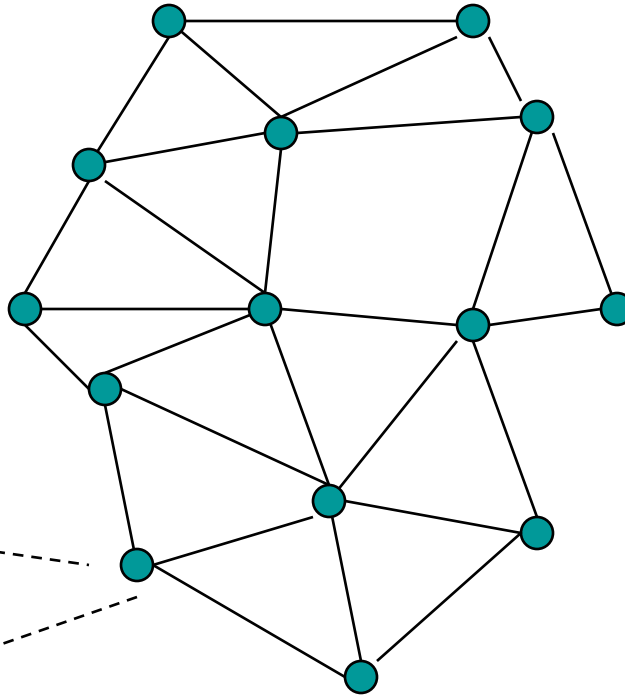
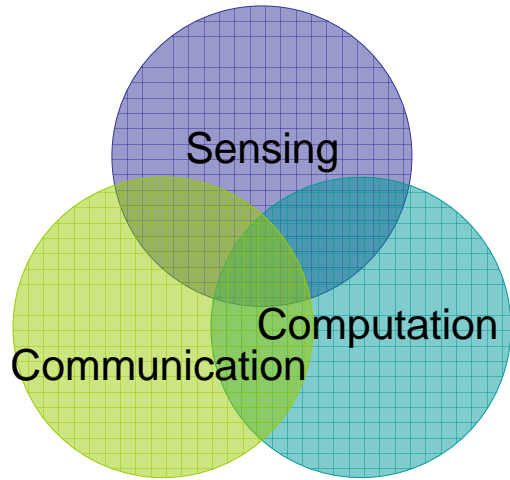

mote

- Integrated Humidity, Temperature and Light sensors
- 8MHz Texas Instruments MSP430 microcontroller
- 10kRAM, 48k Flash
- 250kbps 2.4GHz IEEE 802.15.4 Wireless Transceiver

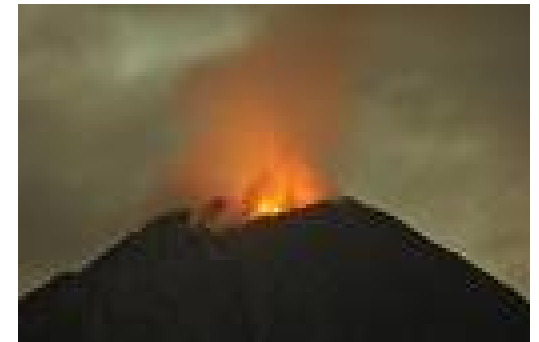

VolcanoNet



BridgeNet



TurtleNet

What are mote-based wireless sensor networks?

- Discovery
 - Finding neighbors, gateways, and services
- Networking
 - Routing data to gateways through a mesh of motes
- Communications Paradigms
 - Query-Respond: Gateway queries network for data; motes respond
 - Event Triggered: Gateway configures motes to respond upon some event happening
- Low-Power Strategies
 - Low Power Sleep Modes: 10-20 uW for radios; 5-10 uW for processors
 - Duty Cycling: synchronous sleep scheduling
- Management
 - Remote Configuration: Gateways issue commands to change parameters, which alter mote behavior
 - Remote Programming: Gateways send software updates
- Collaborative/Distributed Computation
 - Localization, Aggregation, Object Tracking, Sensing

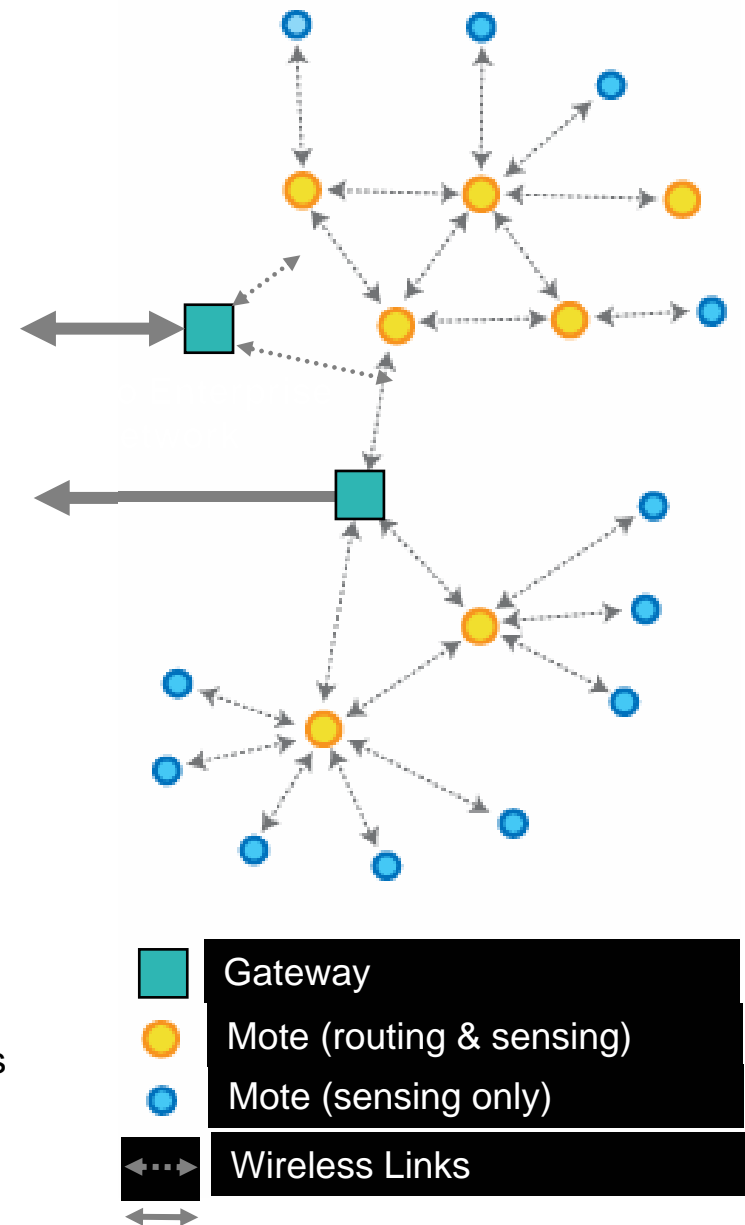

Bridge Monitoring

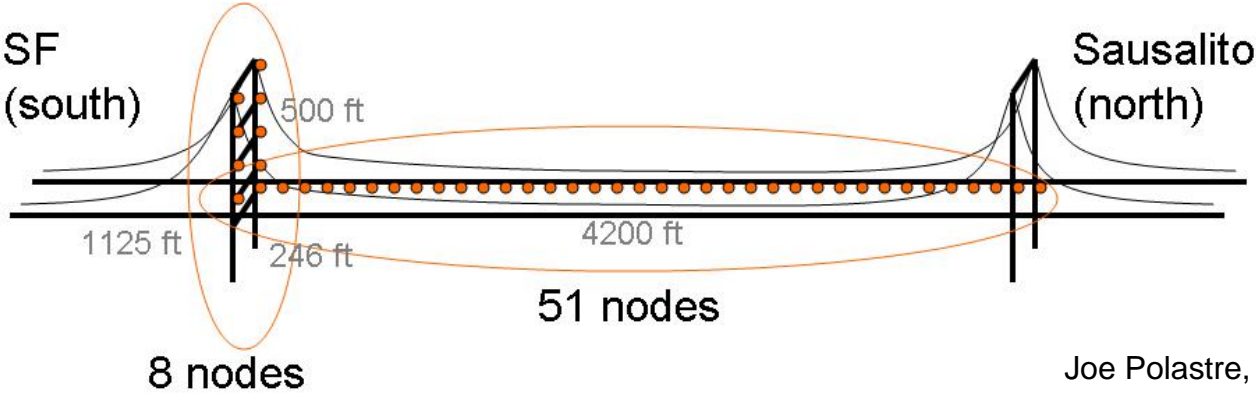

2005

Joe Polastre, CTO with Sentilla

Rail Car Monitoring



1 - Continuous real-time capture and analysis of critical and periodic sensor data ;

- wheel bearing temperature trends + other sensors
- operational data - manifest verification, car drop-off location and time, freight condition

2 - Event publication ;

events, alerts and alarms to locomotives local crews and the enterprise

Train Linear Mesh Network

- Motes are mounted on the railcars.
 - Transmission range R of each mote covers multiple cars
- Gateways are installed at the locomotive
 - One train may have one or more gateways

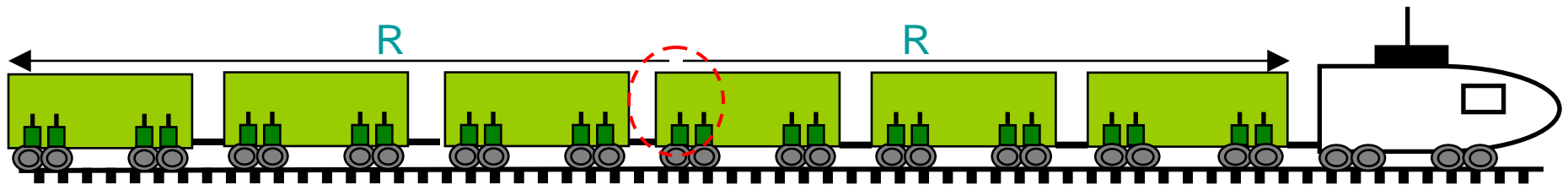

- Multiple hop linear mesh network

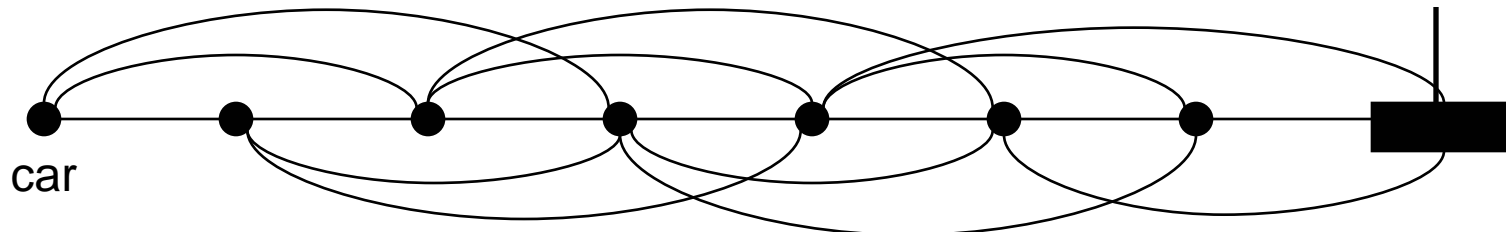

Overview of Rail Application

- Focus on **freight** trains.
- on operational and economics
 - Railcar tracking
 - Failure detection
- Sensor networks
 - Real-time data
 - Online processing



Railcar
Tracking

Consist
orientation

Bearing
temperature

Weight
distribution

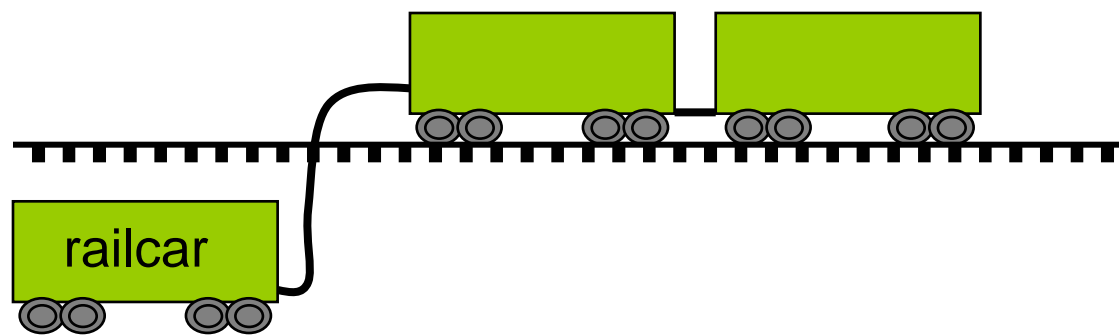

Scenarios used to design the WSN Rail system (partial)

1. **Hot Box Detection***
2. Air Pressure and Brake Monitoring
3. EOT Function
4. Wayside Gateway
5. Order of Cars in Consist (and orientation)
6. Determine Length of Consist
7. Connect/Disconnect Car Detection
8. **Dark Car Drive By***
9. Access Customer Cargo Data
10. Intrusion/Tampering Detection
11. Determine Weight of Train
12. Gateway and MOTE Network Remote Management, Configuration and Auto Provisioning*
13. Installation and Testing
14. Repair and Replace in Field
15. Emergency Messages, Event Notification*
16. Send External Notifications
17. Capture and relay sensor readings and control parameters*
18. Carry experimental data from *ad hoc* sensor platforms
19. **Hazmat** Location, Condition and Tamper Detection
20. Bio/Chem/Rad Detection
21. AEI tag integration

* Original scenarios

Sensors in motion on Trucks and Bearings



Temperature

Weight

Vibration

Speed Location

Acoustics – (flat wheel)

Tampering – (open Lid)



Motes connected to sensors can have different roles and modes

- Sensing Configuration
 - Additional bearing sensors attached sensor interface
 - Air pressure-based power subsystem
 - Does not perform routing
- Forwarding Configuration
 - No bearing sensors attached to sensor interface
 - Solar-based power subsystem
 - Performs routing
- Periodic Reporting
 - Technique used to improve reliability and reduce energy consumption
 - Basic concept is to trade-off latency for reliability
 - Applicable to applications that have a latency tolerance greater than real-time
- Alert Reporting
 - Technique used to report critical events in near “real-time”
 - Requires low latency

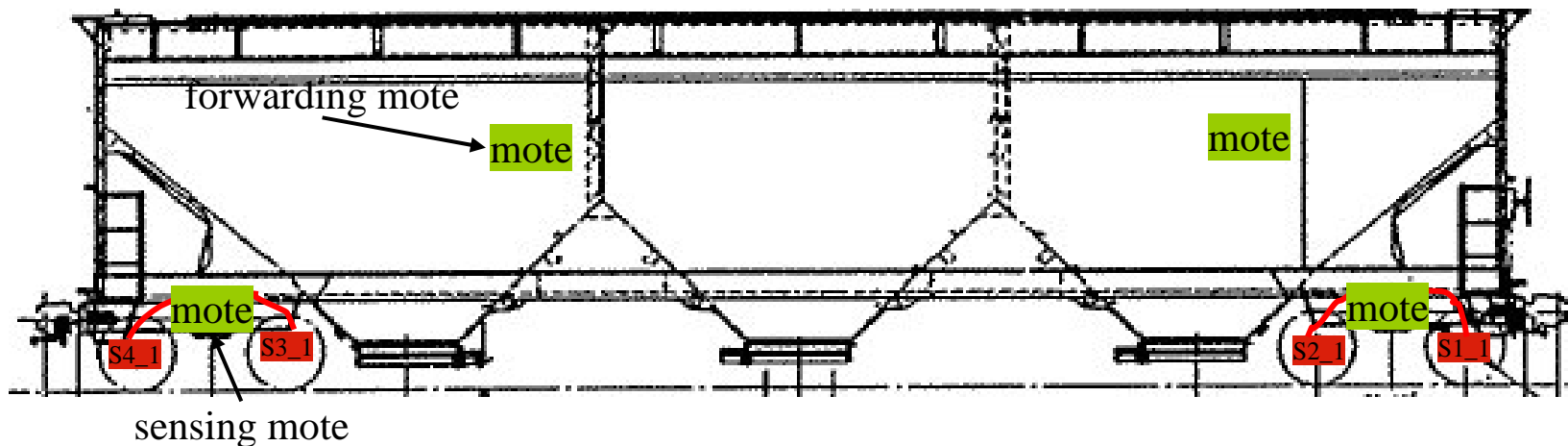

Connecting to the enterprise

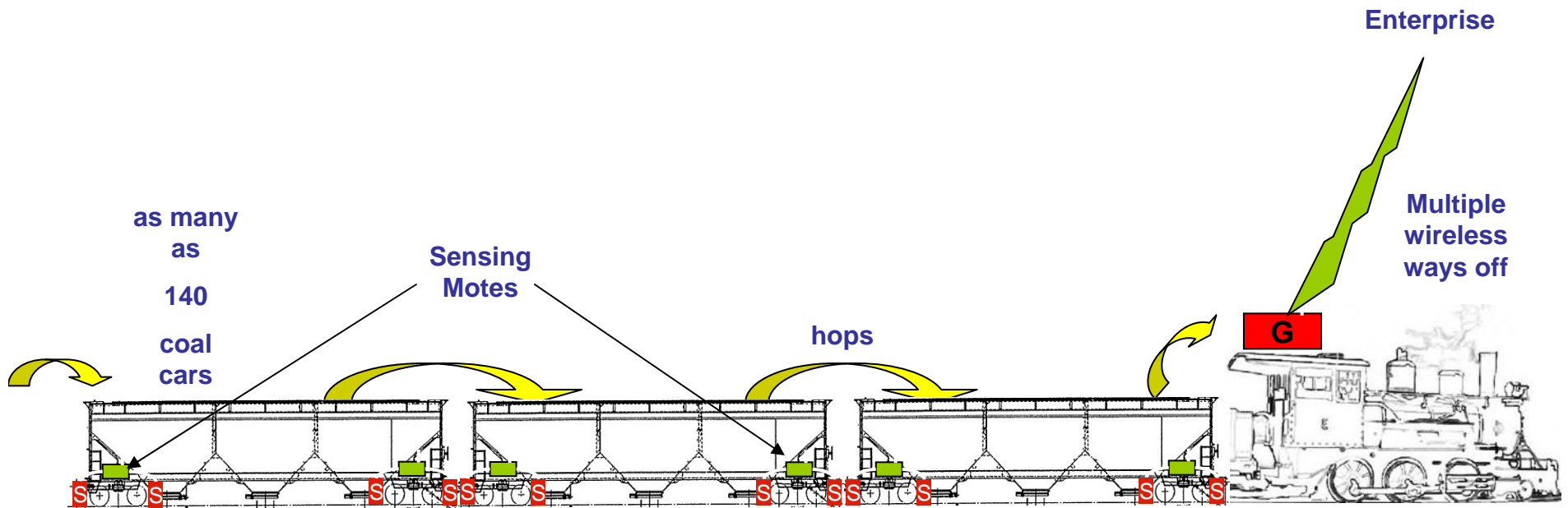

Connecting to the enterprise (side)

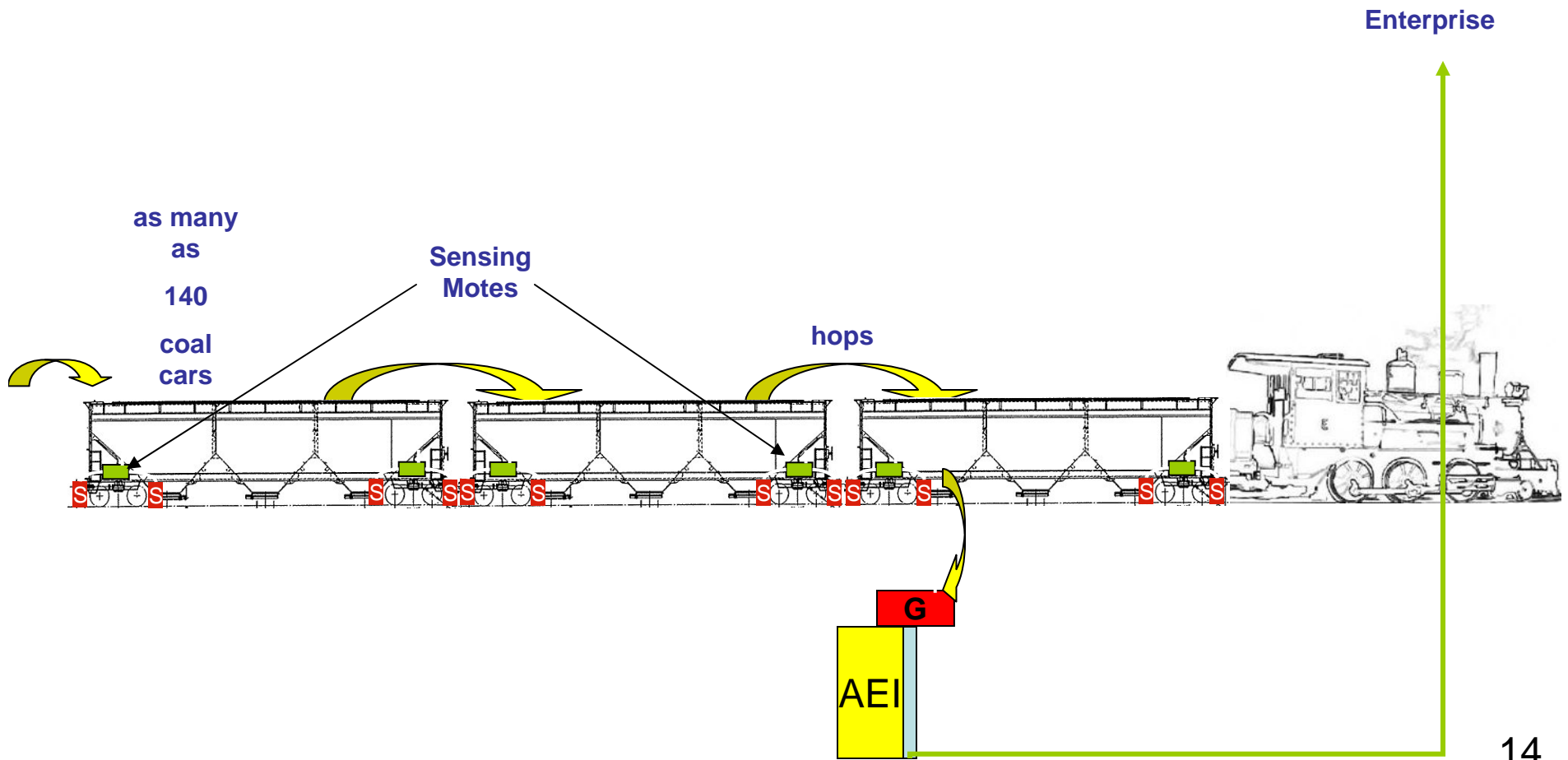

Rail Car Monitoring Vision

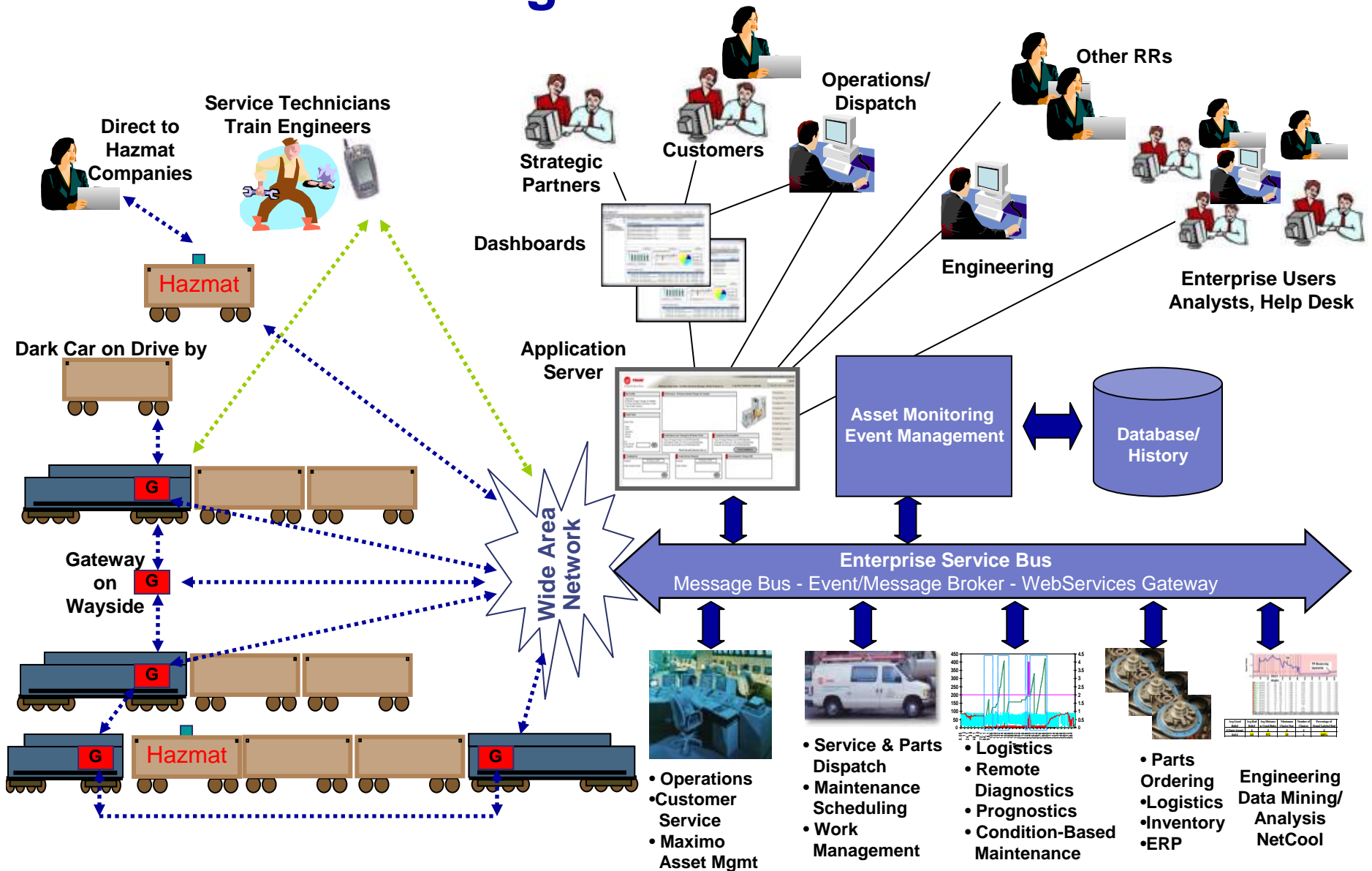

Main Lines Yards, Trains & Customer Assets

Enterprise Business Systems, SOA Components, Applications and Users

User view of a consist, with drill down manifest, car type orientation, sensor data, calculated data and alarms

The screenshot displays a software interface for managing a train consist. At the top, there are tabs for 'CONSIST', 'CARS', 'ALERTS', and 'DEFAULT VIEW'. Below these are controls for 'Floor4', 'All', 'Sound: Off', 'Hide: No', and a 'Save' button. The main area is a map showing a train route from Seattle to St. Louis. A train consist is overlaid on the map, consisting of an engine, several box cars, a hopper, and a tanker. A 'Car Detail' window is open over one of the cars, displaying the following information:

Category	Value
Car type	HTUnitTrainHopper
Car id	RC_RTF0001
Order	0
Consist	TBD
Mote id	RC_RTF00011003
General	
ID	RC_RTF0001
Label	HTUnitTrainHopper
Alert	no
Motes	
MoteTruck	RC_RTF00011003
MoteTruck	RC_RTF00011002
generalization	
RailCarGeneric	RC_RTF000110
BearingTemperatureRGT	null degreeF
Speed	null mph
RearTemperatureFT	null degreeF

An Even Bigger Picture

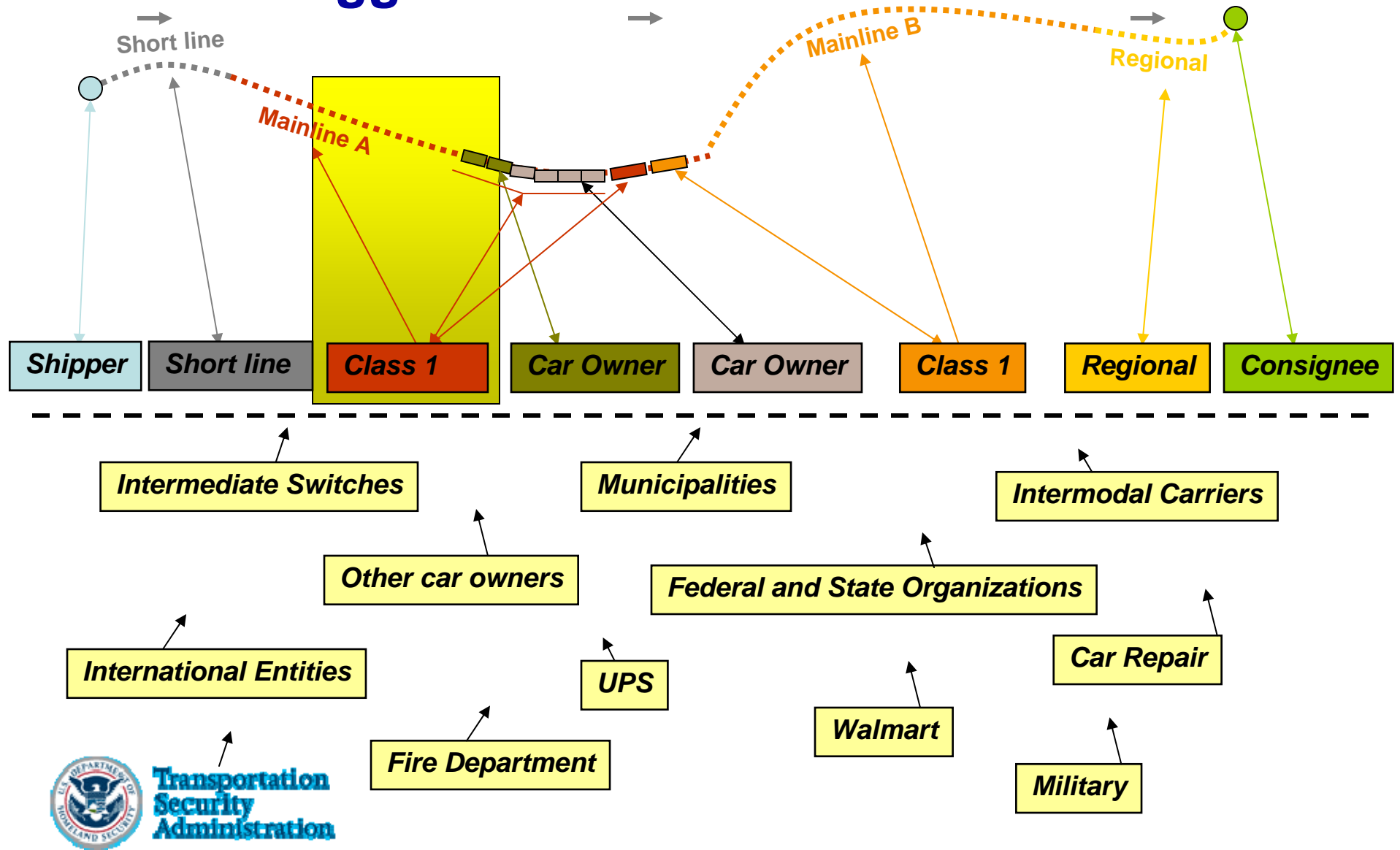

A Terminal Asset and Freight Monitoring Vision

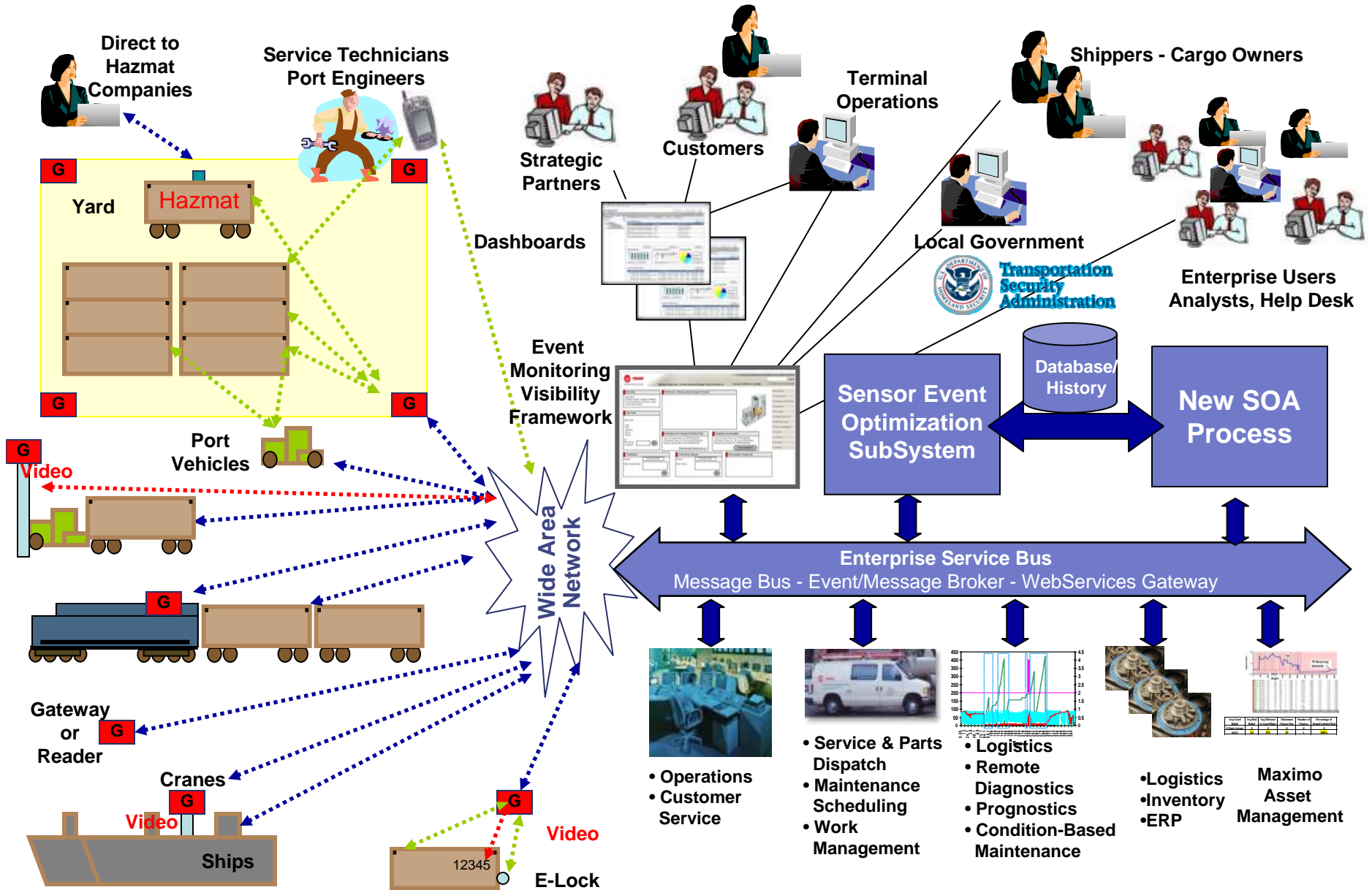

Terminal - Trains Ships Cranes Trucks Assets

Enterprise Business Systems, SOA, Applications and Users

A Terminal Asset and Freight Monitoring Vision

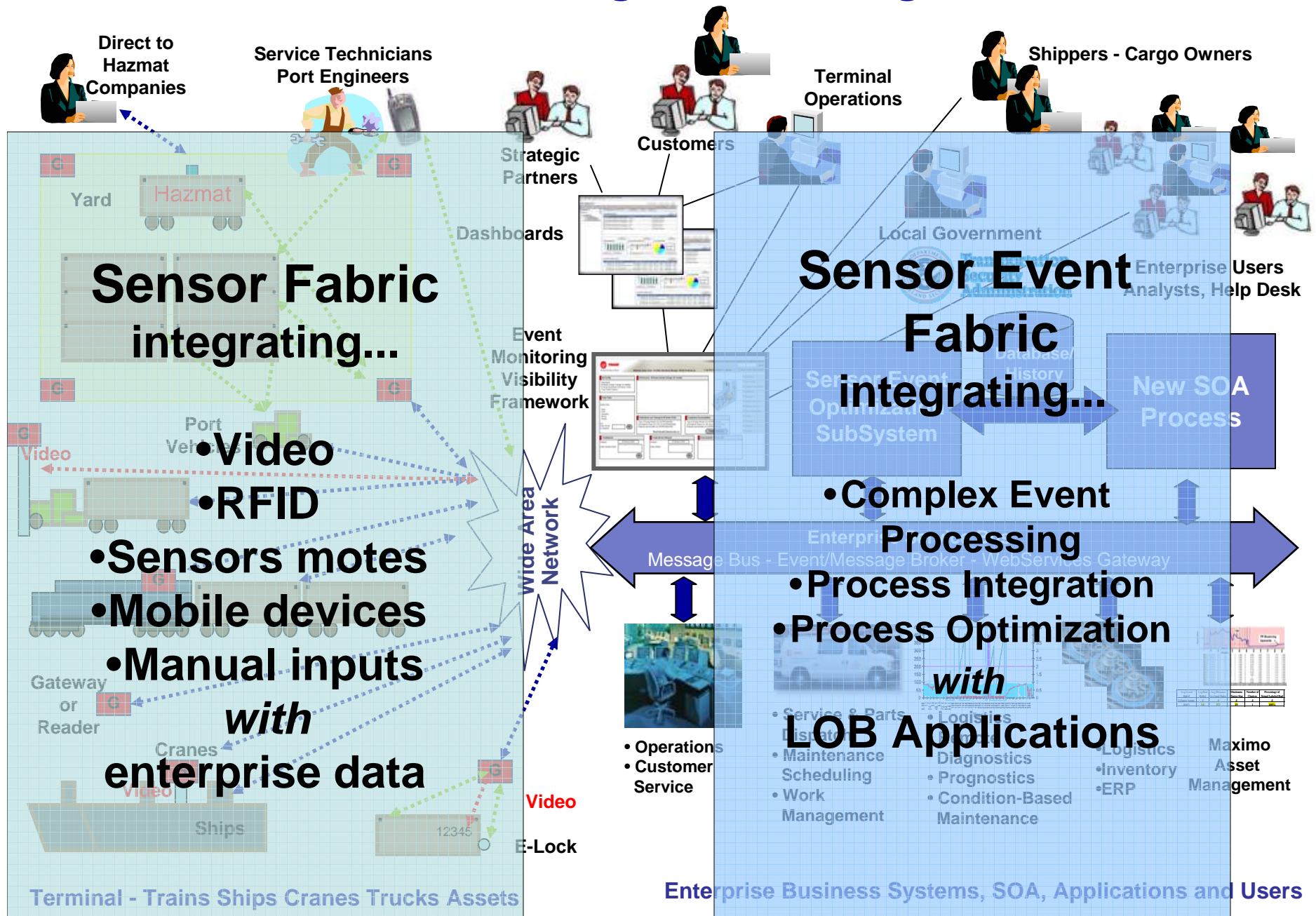

Very Harsh environment



AEI tags and readers have been out there for 15 years



SmartPass Reader can read both Passive and Active AEI tags



Next Generation Motes

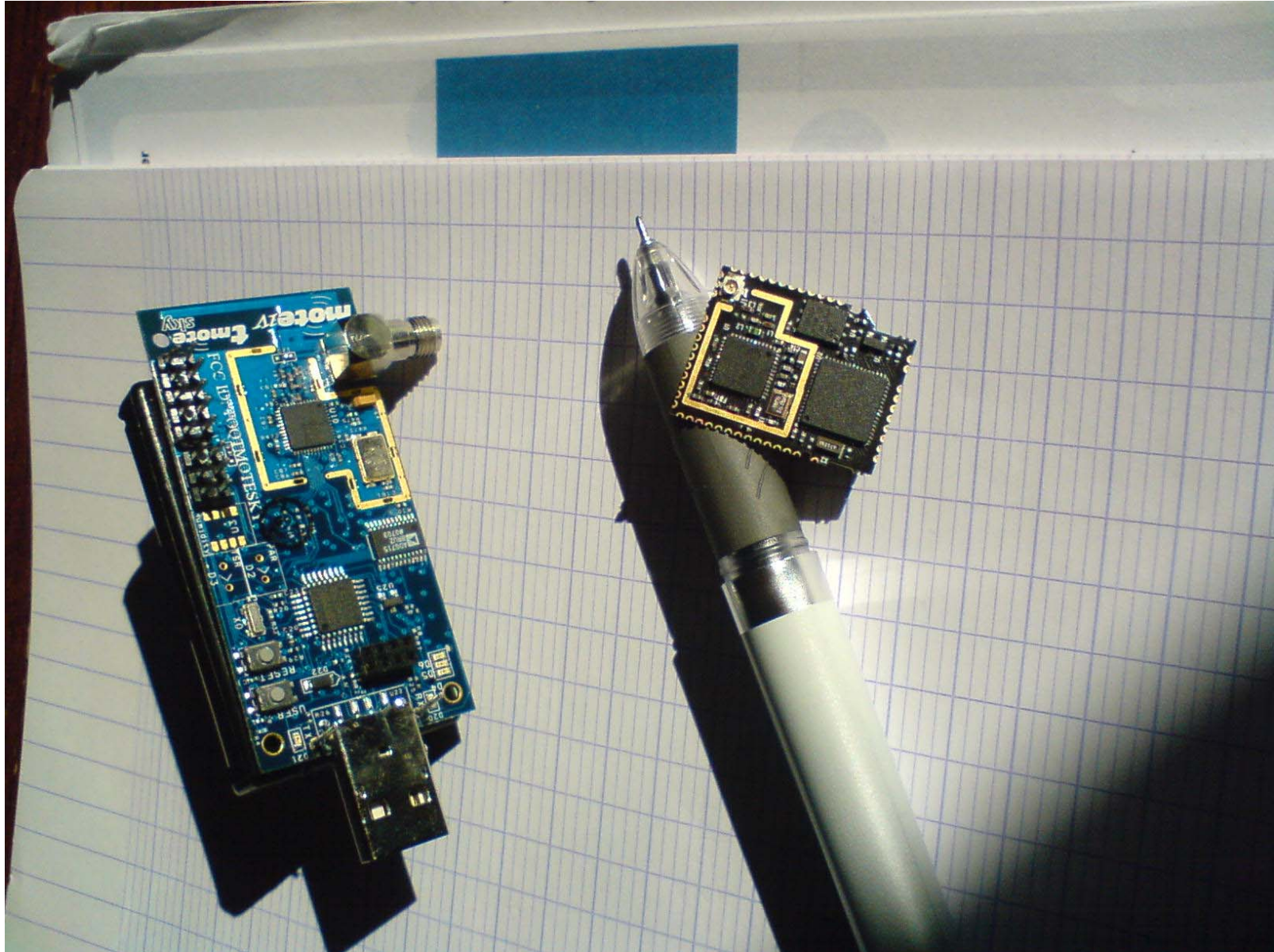

WSN Solutions require Mote platforms that are complex

- Main modules: Tmote, Power-Memory-Interface (PMI) board, solar panel, sensor board, and GPS module
- All other components are integrated on the PMI or are connected to the external sensor interface
- Modular design: Tmote, sensor board, power scavenging with solar panels, or any of the external sensors can be replaced with any alternatives that adhere to the same interfaces
- External analog sensors attach via micro screw I/O terminal
- External sensor lines are addressable over I2C bus

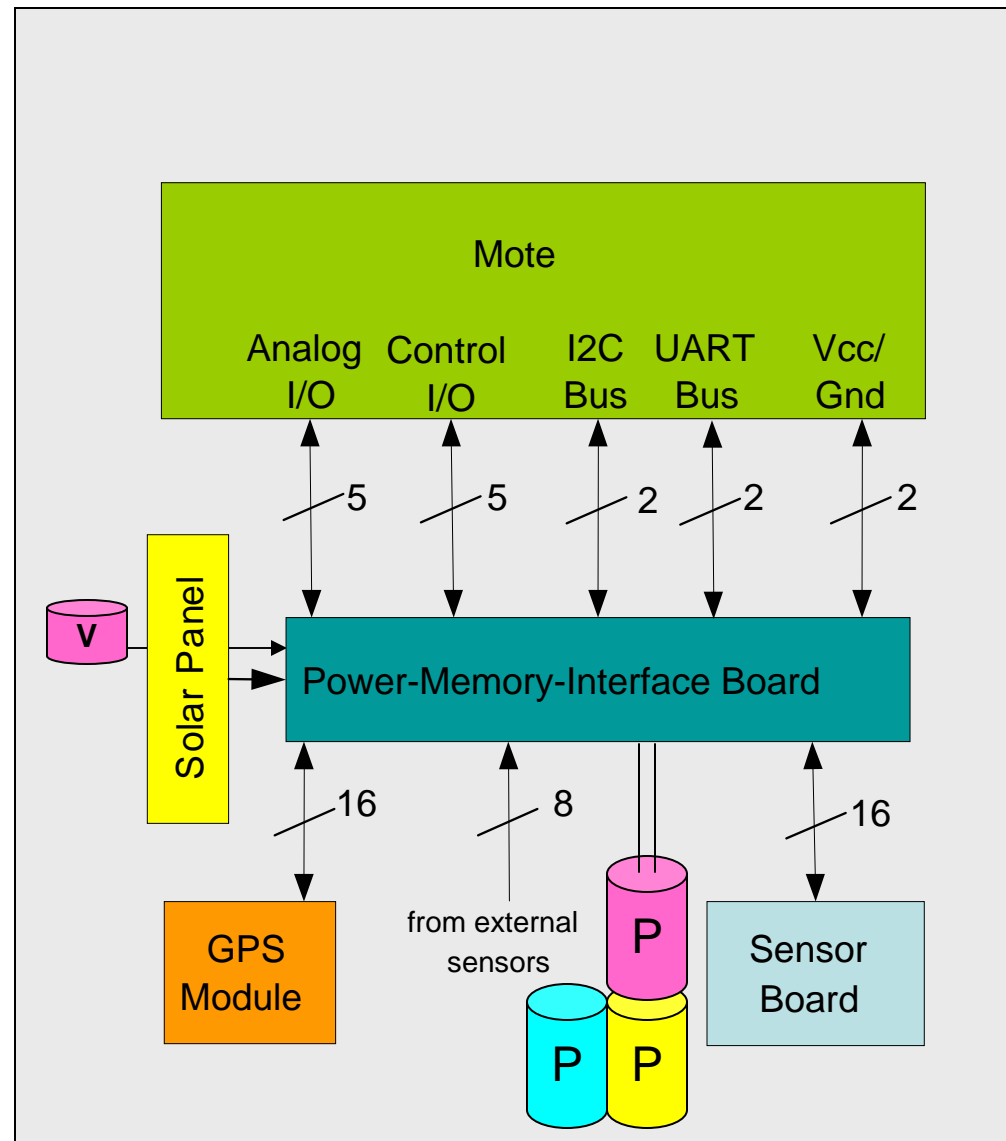



e-business

Six steps to Deployments for North America

1. **Lab Prototype** (November, 2006. through November, 2007): Initial Mote implementation working in lab setting, but not necessarily in a railroad environment. Gateway integrated with Motes. Interim deliverable (TBD) late June (consist join/dis-join, dark car)
2. **Field Testing** (February, 2008 through August, 2008): MOTES enclosed to operate in a railroad environment. Measurements and evaluation exercises in a controlled railroad environment. Gateway to enterprise communications implemented. Both wayside and engine-hosted gateway configurations will be tested. Validation of business case.
3. **Deployment Prototype** (March, 2008 – October, 2008): MOTE hardware redesign for reduced manufacturing cost incorporating lessons learned during field testing. Continued improvement and refinement of Gateway to/from enterprise inter-operation, and integration to enterprise systems.
4. **Pilot Deployment** (November, 2008 – June, 2009): Initial deployment of MOTE sensor network into an operational environment on a limited basis to continue to identify and correct hardware, software, and system short-fallings. Identify and correct any emerging performance issues with the system. Re-validation of business case.
5. **Production Platform Manufacturing** (concurrent with Pilot Deployment): Working with one or more manufacturers of devices (MotelV, Arch Rock, Crossbow). Additional engineering challenges need to be identified and addressed. Any production platform must be made with a standardized sensor and power interface as specified by the architecture.
6. **Production Roll-out (TBD)**: equip railcars with MOTES and sensor packages, install rail-side gateways, and start installing engine gateways.





Thank You -- Questions ?

John Dorn

**Wireless Sensor Networks Solutions
Condition Monitoring, Asset Optimization**

+1 917-453-9863

jdorn@us.ibm.com

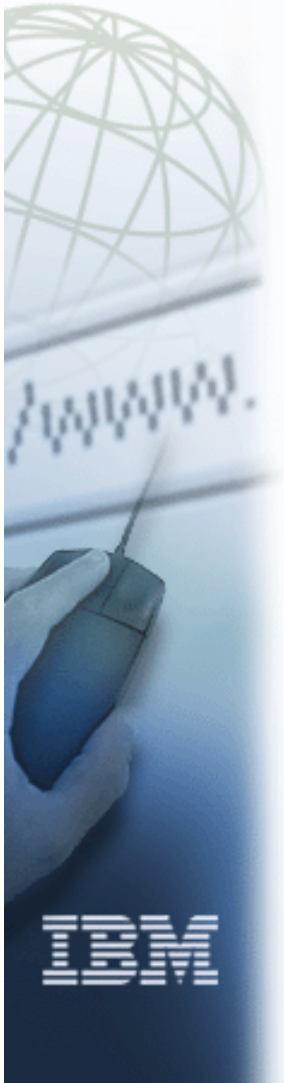



e-business



IBM

Event Optimization: the Next Generation of Condition Monitoring



5. Business Optimization

4. Process Integration

3. Event optimization

2. Event publication

- events, alerts and alarms integrated with operational processes

1. Continuous real-time capture and analysis of critical and periodic sensor data

- operational data - manifest verification, car drop-off location and time, freight condition
- temperature trends + other sensors
- video events and OCR
- Rfid events and data

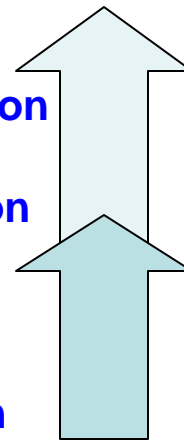

The Bigger Picture – from Railinc.

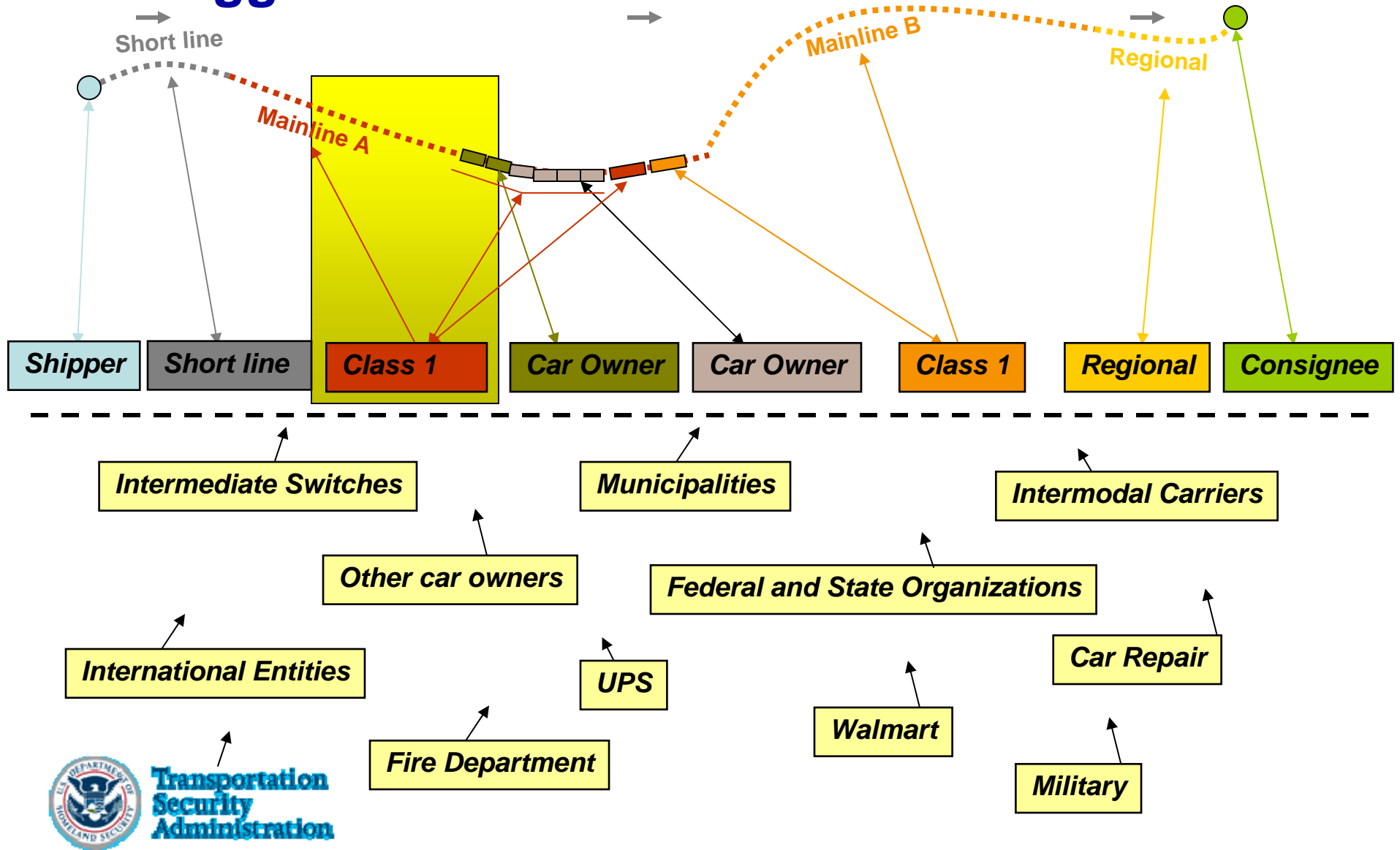

IUN reference architecture for distributed analytics

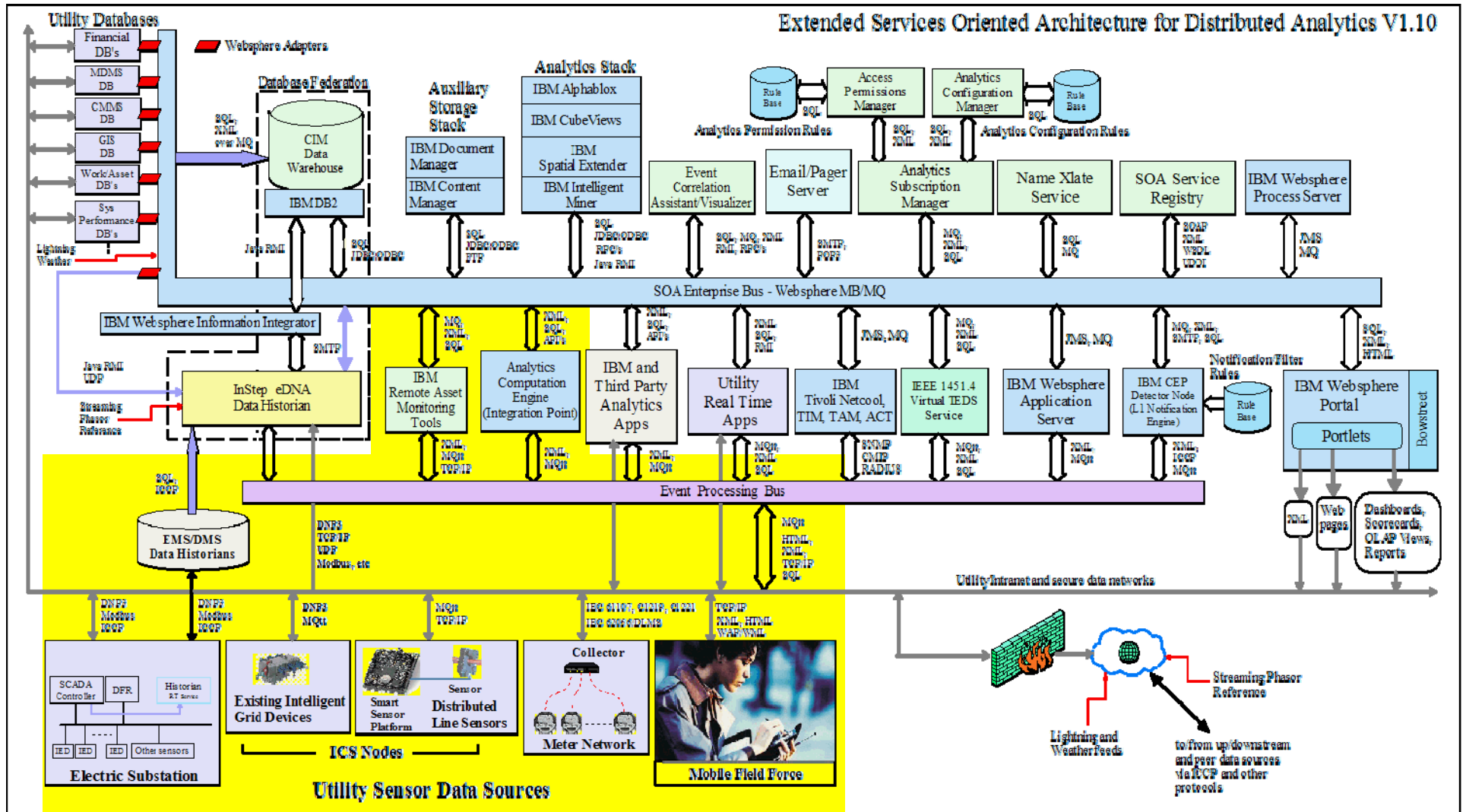

Architectural Approach: Big Building Blocks

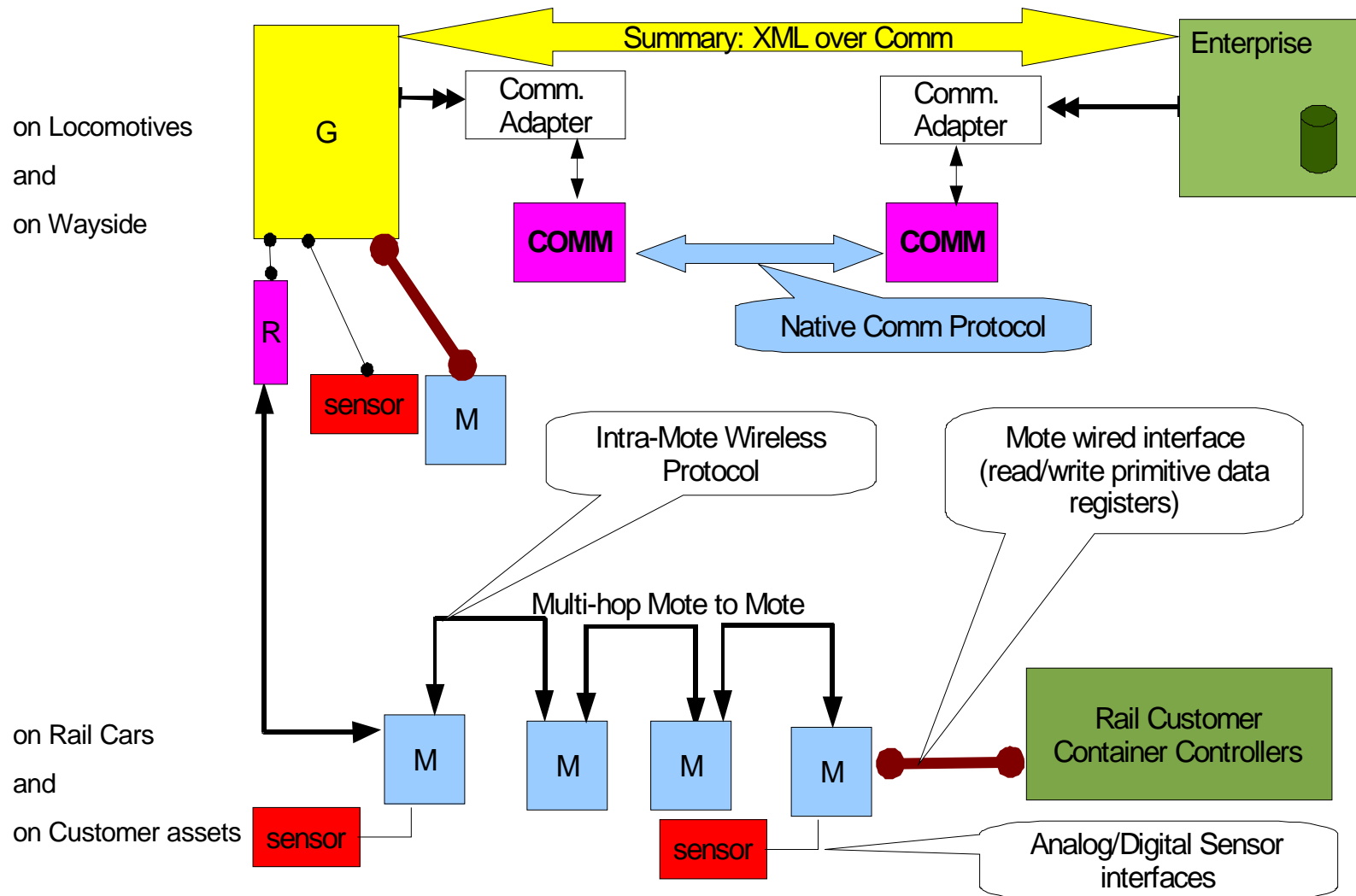

Example layout of Rfid readers at a rail facility

● Approximately 22 Points of Interests

Each RFID point of interest needs a fixed reader and a communications infrastructure

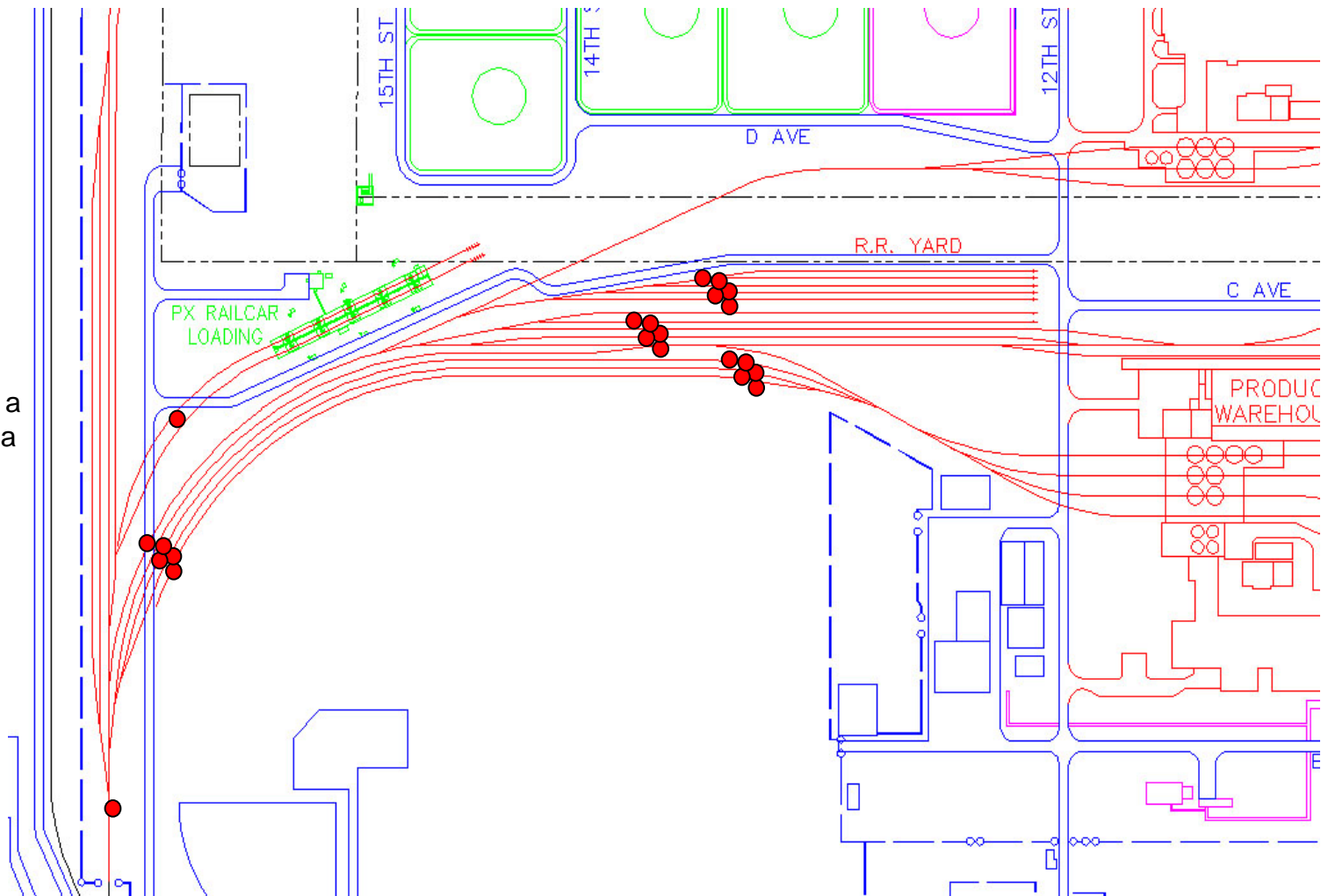

WSNs can have continuous monitoring and periodic event reporting based on a set of rules or conditions that you can specify and change remotely....

● Approximately 22 Points of Interests

Each Rfid point of interest needs a fixed reader and a communications infrastructure

with WSN
Each Point of interest can be a set of calculated events that are programmed into the Wireless Sensor Network and these events can be changed remotely

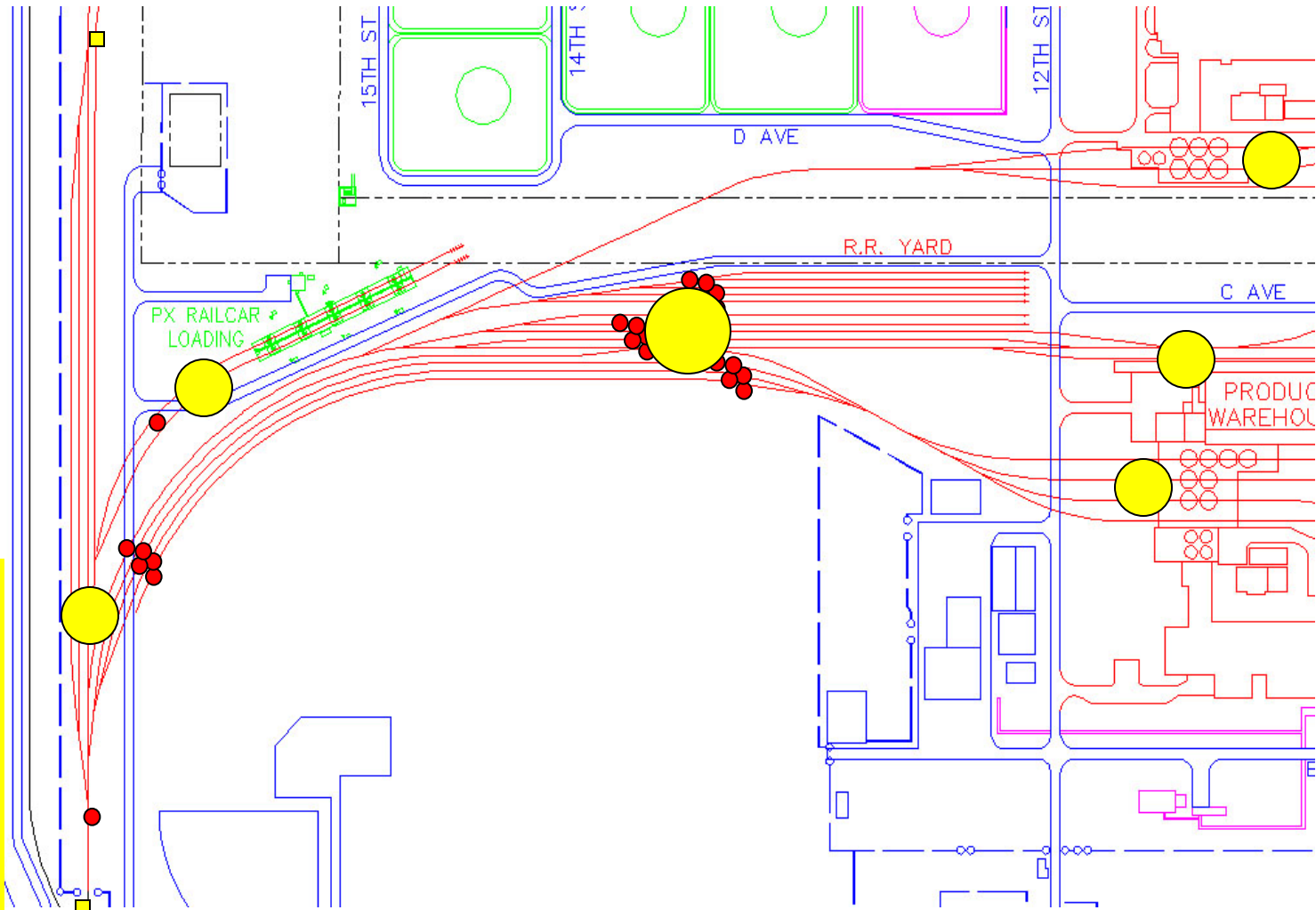

Some of the Challenges

- Very Low power (<40mW) needs Supercaps batteries, small size, cost is ?
- Wireless receive and transmit, 1mW -10mW and internal vs external antennas
- Packaging, mounting, low tech installation, field replacement
- Remotely provisioned, configured on demand, by location
- Remotely managed over a 5+ year life - without being touched
- Power scavenging, charging multiple type cells, and distribution of power to components, sensors
- Very Harsh environment – Low and Very Hot temps.
- Complex event processing at the enterprise